

**A.10.5.**

Innovative installation method using water as a carrying fluid to install power cables in pre-lubricated ducts in trenches of reduced dimensions

C. TRICHARD, Netconcept, France

C. BLANC, Novoplastic, France

G. PLUMETTAZ, Plumettaz SA, Switzerland.

Abstract:

This method consists in using pre-lubricated PE ducts in which frictions are considerably diminished, in injecting pressurized water into the duct to carry the cable forward, thus avoiding the sticking effect due to the electrostatic field, and reduce friction heating, in pushing the cable with caterpillars and pulling it with a shuttle-head or, depending on the cable type, in letting the cable being pushed by the drag of the water flow.

Advantages of this method:

- Cable placing does not depend on the duct building activities: reduced site neighborhood disturbance
- Greater cable lengths between splices or manholes
- Almost no efforts exerted on the cables: greatly reduced installation risks
- Possibility to follow much more complex routes

Keywords: Floating; pre-lubricated ducts; crushing; mobile site

Review: pulling method**Characteristics of the method:**

Presently, electric power cables are pulled into dry ducts, which are lubricated as the cables are being installed. This method presents following inconveniences:

- a) integrity of the cable sheath:
During pulling operations the cable sheaths are subject to severe damages, to such an extent, that some companies have been looking for a device enabling them to check the quality of the thus installed cable on site.
- b) integrity of the duct:
During operation the pulling line can cut into

Résumé:

Cette méthode consiste à utiliser des conduits pré-lubrifiés en PE pour abaisser les frottements, à injecter sous pression de l'eau dans la conduite pour porter le câble, annulant ainsi l'effet de collage dû au champ électrostatique et limitant les échauffements par friction, à pousser le câble par des chenilles et à le tirer au moyen d'une tête faisant furet ou, selon le type de câble par la traînée provoquée le flux d'eau.

Avantages de la méthode :

- Insertion des câbles indépendante du génie civil des conduites : impact réduit des chantiers sur le voisinage.
- Plus grandes longueurs de câbles sans jonction ni chambre
- Pratiquement plus d'efforts sur les câbles risque d'installation considérablement réduit
- Possibilité de parcours beaucoup plus complexes.

Mots clés: Flottage; tube pré-lubrifié; broyage; chantier mobile

the duct walls over bends, sometimes cutting right through the walls.

- c) installation setup:
The forces encountered with this method, often require line-pulls of several tons applied at the head of the cable and exerting mechanical stresses on it, and the use of powerful, cumbersome and costly means.
- d) installation lengths:
Installation lengths depend on the sinuosity of the route and this in all directions. The pulling method, where the traction force is exerted at the cable extremity, is particularly penalizing. Indeed, the pulling force grows exponentially as the cable passes over bends. It can rapidly



reach the maximum installation load allowed for said cable, thus severely limiting the installation lengths over tortuous routes.

- e) disturbance of the neighborhood:
The use of these powerful means produce important obstructions in the traffic lanes and occupy large ground space, with increased inconveniences for the neighbouring population during the whole duration of the works.
- f) removal of cables by pulling:
Such an operation is very questionable under these conditions and in most cases impossible.

Pushing/floating cable installation method:

In order to offer a truly improved cable installation method, it seemed necessary to involve all actors concerned:

- power cable supplier
- civil engineering specialist
- manufacturer of pre-lubricated plastic ducts
- cable installation machine constructor
- radically different cable installation method

Technical improvements brought forth by the various actors:

- a) Power cables:
The evolution of installation techniques allowed to validate the placement of lighter power cables with lesser mechanical resistance
- b) civil engineering:
with ducts offering increased mechanical protection, trench dimensions can be reduced. Furthermore, on-site crushing of the dug out material, in order to re-use it as backfilling, is also cost-saving, as need for off-site backfilling material becomes redundant.
- c) pre-lubricated ducts:
The coefficient of friction of a manually lubricated dry duct is of approx. 0.12, whereas that of a duct with inner Teflon coating is of approx. 0.06, hence the friction forces are greatly reduced, particularly in bends where they grow exponentially [1].
- d) pushing-floating installation method:
The idea of replacing air by water has been in use for about fifteen years in the telecommunications field. It allowed for increased installation distances by a factor of 4 to 10, depending on the sinuosity of the route, and at the same time for reduced installation time and personnel, especially at the duct end [2] [3].

Operating principle:

There are two possible operating modes, depending on the duct size: either pushing-floating, or pushing-floating-pulling. However, the operating principle of the two modes basically remain the same.

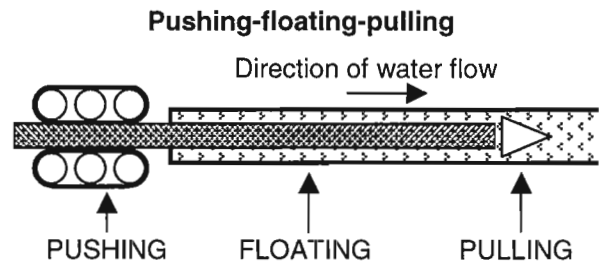
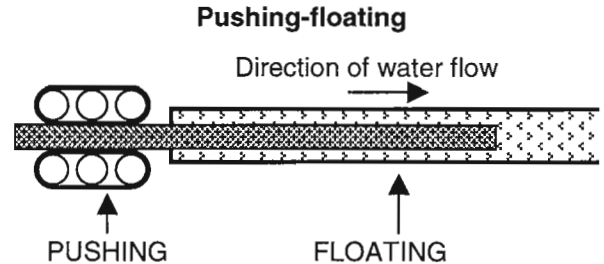

Installation by pushing and floating the cable is safe for personnel and equipment alike as:

Installation forces are distributed and kept low by:

- Pushing the cable at the duct inlet
- Taking advantage of the Archimedes uplift forces exerted on the cable, due to the presence of water in the duct. Said uplift will reduce the friction forces caused by the weight of the cable as normally encountered in dry ducts.
- Using the drag forces exerted on the cable by the water flow, or using a shuttle to pull the cable.

These installation modes are also efficient as:

- One installation team is needed at the drum side only (cable inlet side) with the following tasks:
 - o Monitoring of the correct feeding of cable into the duct
 - o Uncoiling the cable drum
 - o Operating the water supply pump and injection device, operating the cable pusher
- The installation speed can reach 50 m per min. depending on drum size and weight, also on quality of drum handling equipment.

Types of installed products:

Particularly medium-voltage cables are available on the market, either as single phase elements or three-



phase twisted assemblies. Thus there are 2 possible installation modes:

- Installation of single-phase cables in three individual ducts sheathed together:



This arrangement is particularly convenient for the installation of large lengths of about 3 km, with few splices.

- Installation of three-phase twisted cables: Three-phase elements are installed in one duct, which may have certain advantages considering site conditions. However, the installation lengths cannot exceed 1000 meters, mainly due to the size of the drum needed to transport the three-phase twisted cable.



Accomplished test trials:

Triäl circuit:

- Length of one loop: approx. 460 m
- Length of laid cable: approx. 1900 m
- Number of traveled loops: 4

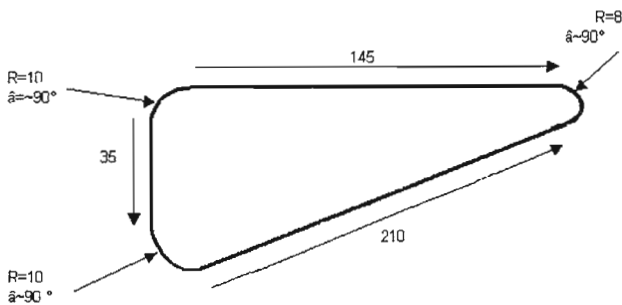

Test results

- Cable reference EDF 240 N 23 (cable 2000)
- Weight 1.6 kg/m
- Outer diameter 37.4 + - 1 mm
- Apparent weight in the water: 0.51 kg/m
- Duct dimension: 50mm outer diameter, 41mm inner diameter.

Installation mode: floating/pushing

- Total installation forces in operation: 250 daN
- Cable sheathings not damaged
- Interior duct walls not spoiled

(the operating forces exerted by pulling within such a circuit in manually lubricated ducts would have been of approx. 4 tons at the cable head)

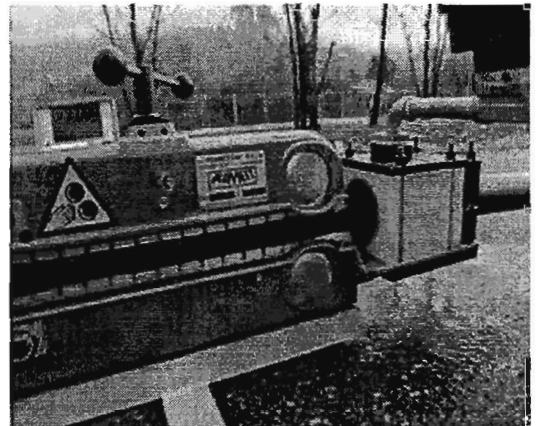
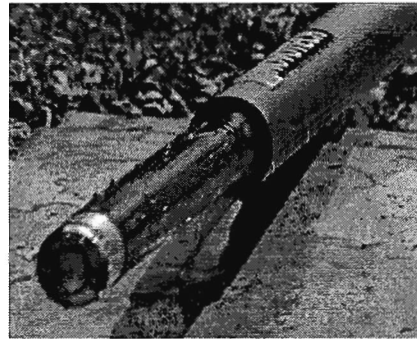

Installation of a three-phase medium-voltage twisted cable by pushing-floating-pulling:

380 m of three-phase twisted cable of 240 mm² of HN 33 were installed following above circuit at a speed of 10 to 20 m per minute in a duct of 110 mm outer diameter, permitting to consider installations of approx. 1000 m in standard circuits.

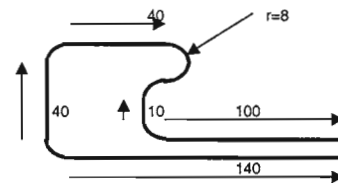

Distances en mètres.

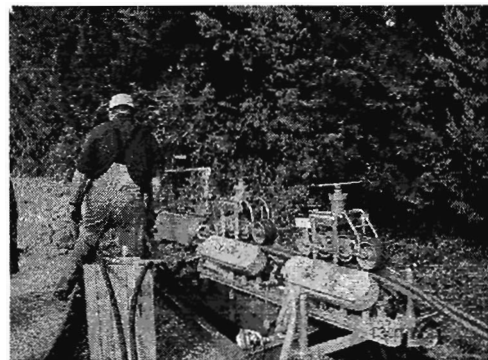



Work site of RENNES carried out for EDF

The work site of Rennes consisted in the installation in urban zone of approx. 15 km of medium-voltage cable of 240 mm².

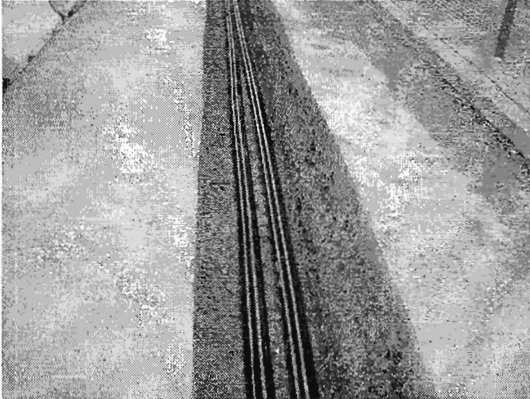

3 lengths of 1,5 km were to be installed over a tortuous route presenting level differences of about 15m.

Three lengths were installed without difficulties, thus confirming the results obtained on various test work sites checking out the working process and associated materials.

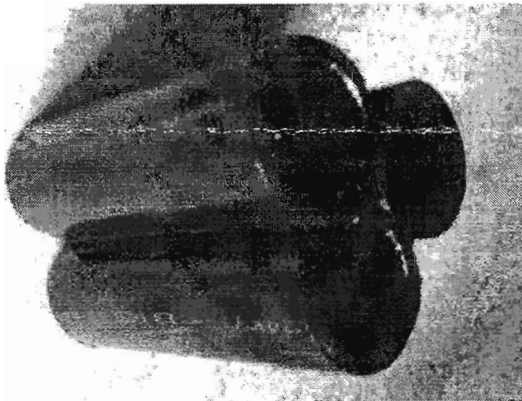

Work site in BEAUNES

The task was to install a street lighting site with 45 km of single-phase cable in three individual ducts sheathed together.

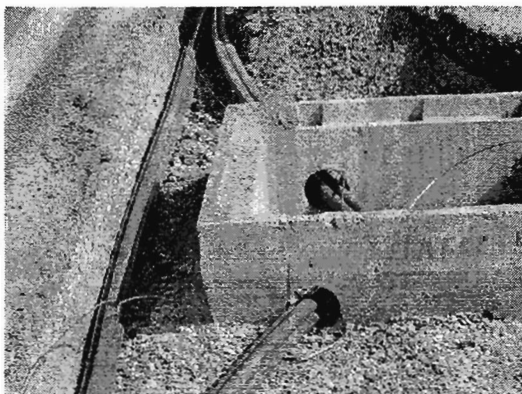

Average lengths installed: 1500 m

Speed: 50 m per min.

High-voltage cable installation trial

This trial consisted in pushing-floating-pulling a high-voltage cable in a buried duct over a route as described in the picture below. The high-voltage cable has an outside diameter of 75 mm. The pre-lubricated tube dimensions are 140 mm outer diameter and 118 mm inner diameter

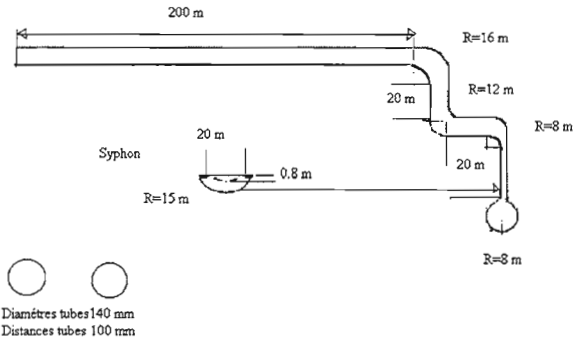

Test results:

Installation speed: 10 m/min

Total installed length: 718 m

Total installation forces: 350 daN

Water pressure at tube inlet: 3,8 bars

NB: the estimated pulling force required by conventional winching is approx. 4000 daN



Conclusion:

An innovating and efficient method for the installation of low-medium- and high-voltage cables into buried pre-lubricated ducts has been validated through experiments and verified in the filed. Compared to existing installation methods, following advantages become evident: reduction of civil engineering costs, mobile sites causing less disturbance to neighborhood, reduction of the number of junctions, ability to install longer cable sections over tortuous routes, greatly reduced risks of damaging the cable during its installation.



References:

- [1] Claude Trichard, PCT WO 02/39560, "*Produit tubulaire allongé, notamment du type conduit d'installation*", 07.11.2000.
- [2] W. Griffioen, "*Installation of Optical Cables in Ducts*", Plumettaz SA Bex (CH) - 1993, ISBN 90 72125 37 1
- [3] P. Mignon, J.L. Campion, J. Le Cam, G. Le Goff, "*Floating, a high performance cable laying technique*", Proc. EuroCable Conference (1999) 200-207.